

VARILLAS					ANCLAJES		TRASLAPE	
Nº	in	mm	cm	cm	cm	cm	cm	
3	3/8	9.52	30	35				
4	1/2	12.70	30	35				

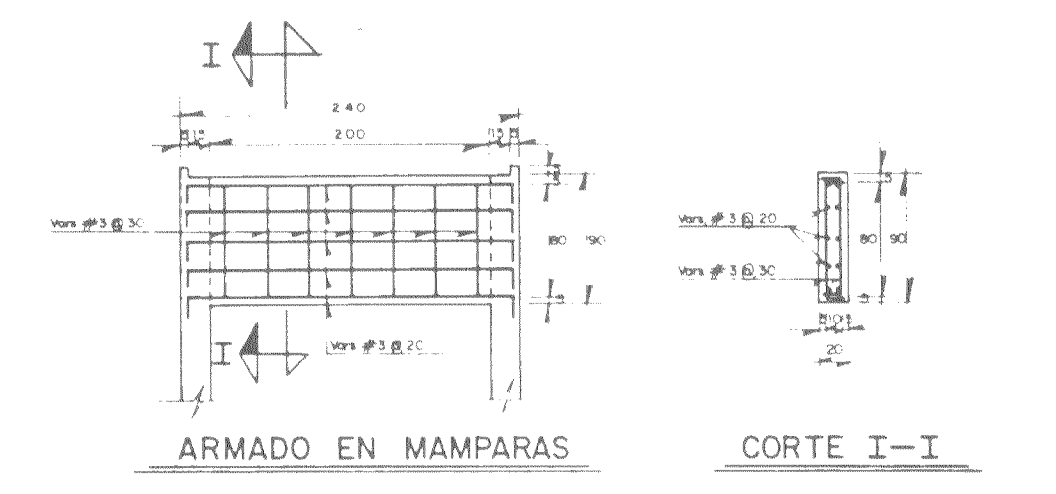
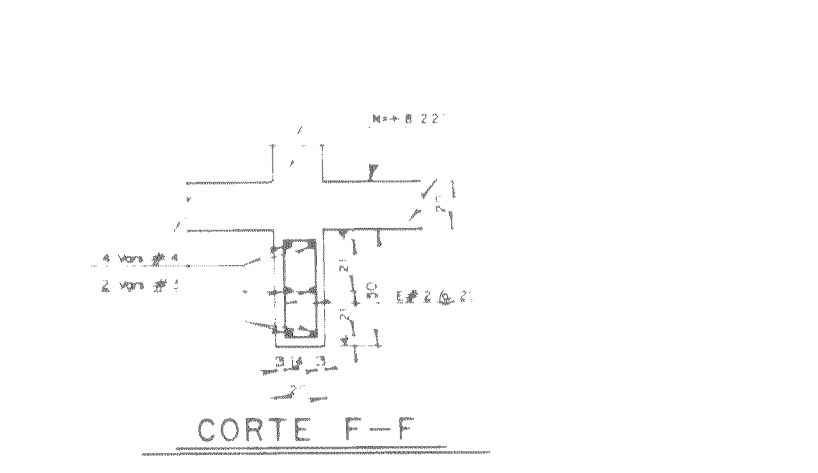
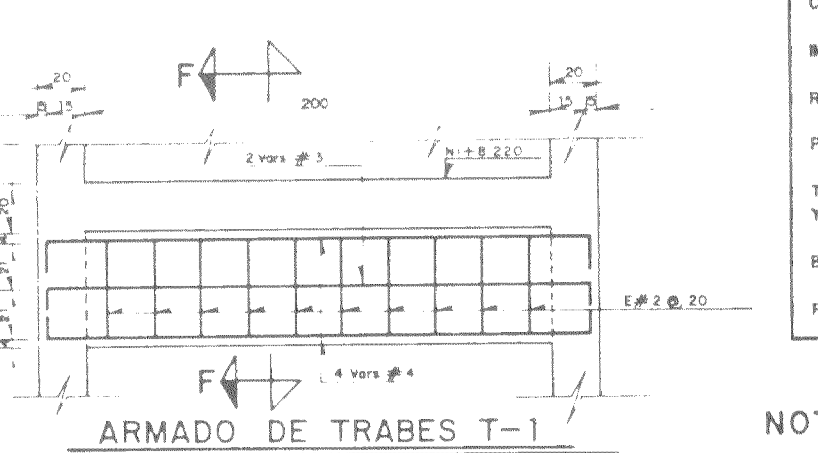
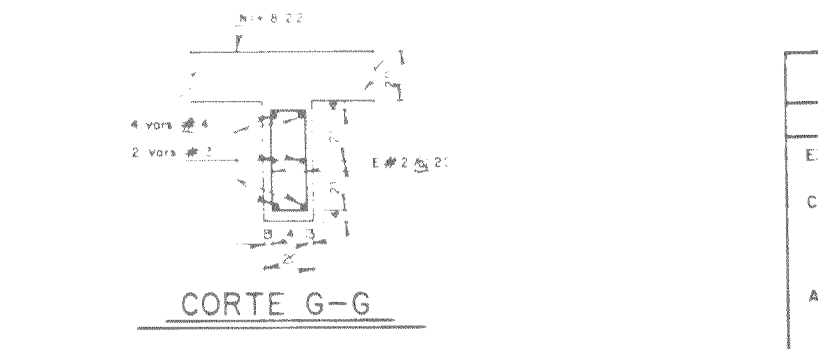
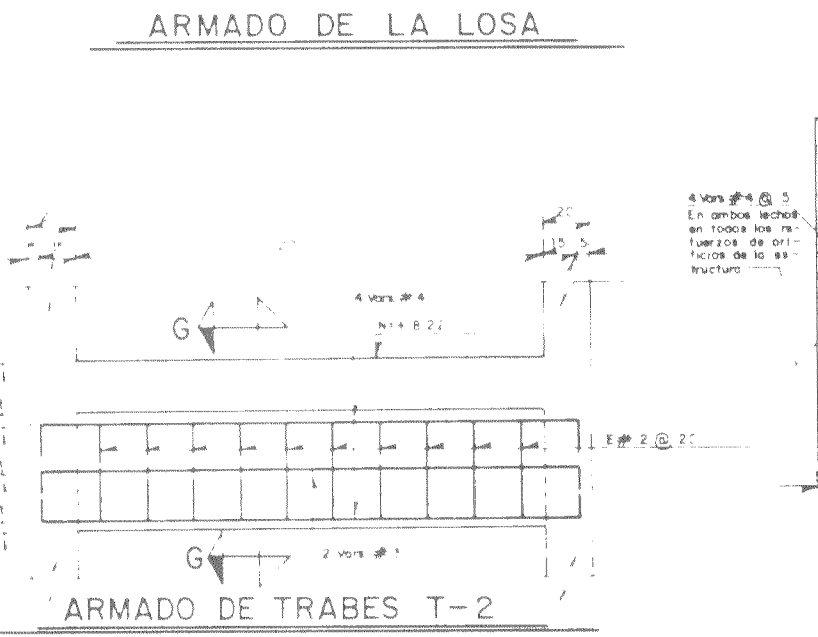
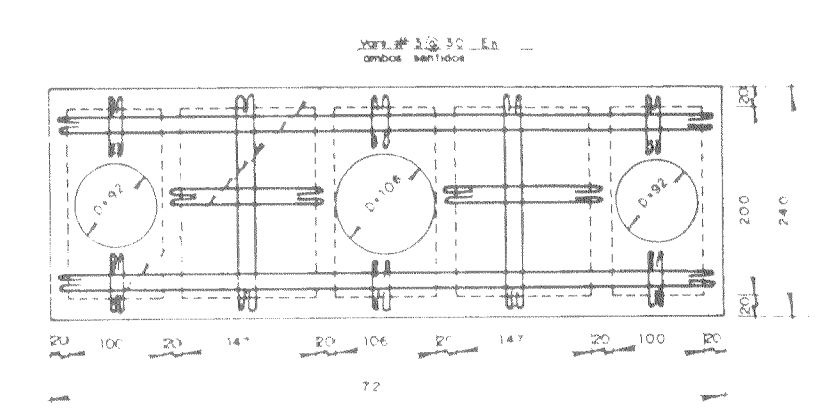

CANTIDADES DE OBRA		
CONCEPTO	CANTIDAD	UNIDAD
EXCAVACION EN MATERIAL TIPO III	5.00	m
CONCRETO		
fc=200 kg/cm² PARA ESTRUCTURA	33.00	m
fc=100 kg/cm² PARA PLANTILLA	1.50	m
ACERO		
fy=4200 kg/cm²	1300.00	Kg
fy=2530 kg/cm²	28.00	Kg
CIERA DE MADERA (SUO DE CONTACTO)	265.00	m
IMPERMEABILIZANTE INTEGRAL	33.00	m
REJILLA DE MALLA DE ACERO IRVING TIPO O SIMILAR	17.00	m
PLACA DE ACERO DE 0.635 cm (1/4") x 20.32 cm (8") Y 20.32 cm (8") DE LONGITUD	47.00	Kg
TORNILLO CON ROSCA ESTANDAR, TUERCA HEXAGONAL DE 1.58 cm (5/8") DE Ø Y 20.32 cm (8") DE LONGITUD	1.4	pezos
BARANDAL DE TUBO DE 2.54 cm (1") DE Ø	1	lotte
PASAMANOS PARA ESCALERA DE TUBO DE 2.54 cm (1") DE Ø	1	lotte

- NOTAS:**
- TODAS LAS ACOTACIONES EN CENTIMETROS, EXCEPTO LAS INDICADAS EN OTRA UNIDAD
  - TOCOS LOS NIVELES EN METROS Y REFERIDOS AL NBM (NIVEL DE BAJAMAR MEDIA INFERIOR)
  - EN TODA LA ESTRUCTURA SE UTILIZARA UN IMPERMEABILIZANTE INTEGRAL TIPO FESTERGRAL O SIMILAR A RAZON DE 0.500 Kg POR CADA 50 Kg DE CEMENTO EMPLEADO
  - CEMENTO A EMPLEAR TIPO 30, ALTA RESISTENCIA A LOS SULFATOS

TABLA DE RECUBRIMIENTOS (en cm.)			
ELEMENTO	Superior	Inferior	Lateral
MUROS	—	—	5
LOSA	3	3	—
TRABES	4	4	3
MAMPARAS	5	5	1
ZAPATAS DE CIMENTACION	5	5	1
ESCALONES	3	3	—

REVISIONES			
FECHA	No.	APROBO	REVISION

PLANOS DE REFERENCIA	
PLANO	TITULO

ELABORADO POR **CONSTRUCTORES Y ASESORES TECNICOS, S.A.**  
 PARA LA **SECRETARIA DE DESARROLLO URBANO Y ECOLOGIA**

DIBUJO: *[Firma]* PROYECTO

REVISOR: ALEJANDRO YTT CALDERON APROBO: ING. R. MORENO ESPINOSA

ING. L. A. GUTIERREZ M. ING. C. MENENDEZ M.

**SUBSECRETARIA DE ECOLOGIA**  
 DIRECCION GENERAL DE PREVENCION Y CONTROL DE LA CONTAMINACION DEL AGUA

**SEQUE**

BIOLOGA ALICIA BARCENA IBARRA      ING. JOSE LUIS CALDERON BARTHELEMY

SUBSECRETARIA DE ECOLOGIA      DIRECTOR GENERAL  
 ING. FCO. BAHAMONDE TORRES      ING. EDUARDO LOZANO JIMENEZ

DIRECTOR DE AREA      SUBDIRECTOR DE AREA

CAJA DE DISTRIBUCION

DIBUJO ELABORADO EN: **MEXICO, D.F.**

FECHA DE ELABORACION:      PROYECTO No.      ESCALA: **SIN ESCALA**

NUM. DE PLANO  
**17**

REVISION No.